

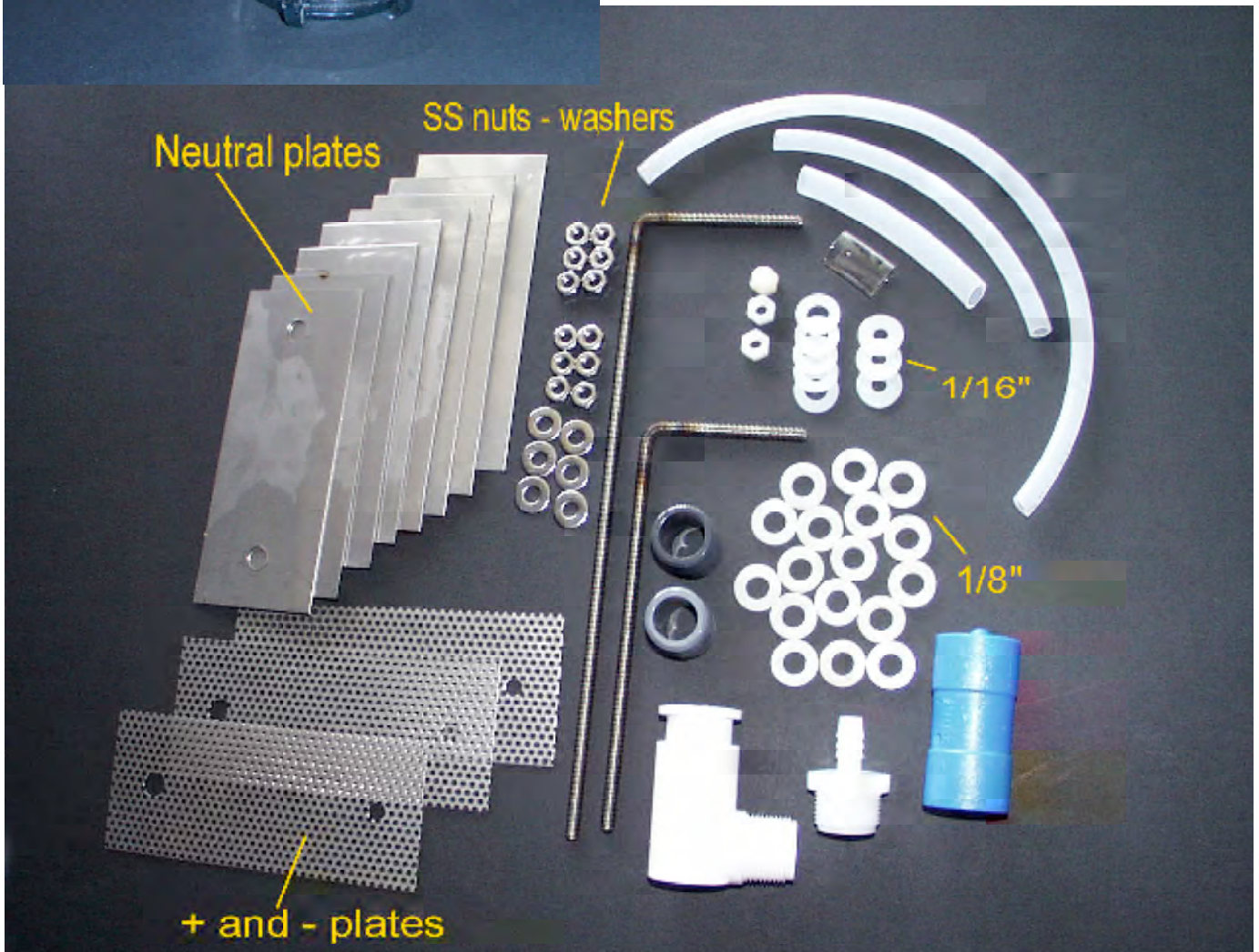

## Instructions for Assembling the II plate "Clear Education Cell"

I hope you will enjoy the education and the awareness of making a hydrogen/oxygen homemade fuel cell. A cell that does not burn one ounce of a hydro-carbon to make it. Unlike the hybrid cells made by the major car manufactures, this hydrogen/oxygen cell runs off of pure H<sub>2</sub>O and 12 volts from your vehicle's battery. It will add a mixture of hydrogen/oxygen to the air intake of your fuel. You can add a MC-12 PWM circuit to the cell, inwhich pulses the DC current & you will produce the magic Brown's Egas. Adding a catalyst to your existing fuel. To start I have to have you read the "Terms & Conditions" from Hydrogen Garage LLC, written by a lawyer, for lawyers and law suits. Since we are liable, we have to cover ourselves the best we can. I also believe in safety. Safety is no accident. All through these assembly instructions we will always be safety first. Respect for the power of hydrogen will always be first. ( This cell design in published and given away to the public, therefore no one can patent over this particular design. Enjoy.)



## **TERMS & CONDITIONS of HYDROGEN GARAGE LLC**

Viewers and users of this website, linked pages, affiliated pages, files, etc. are granted access to and use of the information contained herein under the following conditions.

Hydrogen Garage, LLC grants you a limited license to access and make personal use of the contents herein. The information contained herein is intended solely for educational and entertainment uses. For this reason, no advice or information, whether oral or written, you obtain from this website, and/or affiliated and/or linked websites, whether oral or written, shall create any warranty (express or implied) whatsoever. This disclaimer of liability applies to any damages or injury caused by any failure of performance, error, omission, defect in transmission, computer virus, any unauthorized access and unauthorized alteration of the content herein whether for breach of contract, tortious behavior, negligence, or under any other cause of action. User specifically acknowledges that Hydrogen Garage, LLC is not liable for the defamatory, offensive or illegal conduct of other users or third parties and the risk of injury of injury from the foregoing rests entirely with the user.

By viewing, using, and visiting this website, user acknowledges that any alteration to a vehicle can result in the breach of various warranties provided by their manufacturers, distributors, or sales dealerships. User acknowledges that he or she shall hold harmless Hydrogen Garage, LLC, its affiliates, sponsors, whether in their own personal capacity or representative capacity through corporations, partnerships, and the like in any event a warranty is thereby nullified. Moreover, user acknowledges that he or she is hereby apprised or does already know the fact that various alterations of their vehicle, no matter how minor or insignificant may not be in compliance with the laws of their particular state, jurisdiction, county, or other Federal law. Hydrogen Garage, LLC expressly urges all users to refer to all laws to ensure they are in complete and fastidious adherence therewith. Hydrogen Garage, LLC does not advocate the violation of any laws for any purposes whatsoever. User agrees to use this website contingent upon his or her agreement to abide by all applicable laws.

Furthermore, user is warned that various alterations may be very hazardous especially with respect to the energy systems of the vehicles. Hydrogen Garage, LLC denies all responsibility for any injuries or damages resulting from alterations to the fuel systems. Due to the dangerous nature of working with the fuel or energy systems of vehicles, Hydrogen Garage, LLC expressly warns and recommends that any alterations to their vehicles be made by a licensed, certified, and experienced professional. Moreover, any alterations, and experiments promoted in this site is intended for use on private property (ie. not to be used with publicly subsidized and accessible roads) and exclusively for recreational vehicles. In all cases, user acknowledges and expressly takes the risks attendant to the undertaking of any experimentations or alterations to any vehicle due to the contents of this website.

In addition to the terms set forth above neither Hydrogen Garage, LLC nor its affiliates, whether acting in their personal, representative, or corporate capacity, and their respective officers, directors, employees, agents, attorneys, accountants, consultants, advisors, and partners shall be liable regardless of the cause or duration, for any errors, inaccuracies, omissions, or other defects in, or untimeliness or unauthenticity of, the information contained within this website, its linked pages, sponsors, and affiliates.

All foregoing contents are the sole intellectual property of Hydrogen Garage, LLC. & HydrogenGarage.com

## Preperations :

After washing the plates, acquire rough grit sandpaper, 40-60 grit for scoring the plates with a criss cross pattern, this allows the hydrogen /oxygen bubbles to come off the edges of the soaring. You must use the roughest grit you can find. We buy the black paper, but the red oxide works too. Score the perforated as well. Score both sides, after scoring wash again with soap and water.

## BEGIN ASSEMBLY

Wash Stainless steel before assembly with dish soap scrub all the SS plates and nuts and especially the threaded rod. I use one of those green scoring padded sponges, that you get from your kitchen sink. Steal the old one and tell your wife to buy a new one for the dishes. You want to wash off any oil from the plates and especially the treaded rod that was turned with cutting oil. Any oil left on the steel will result in contaminants in the cell, later Repeat and wash hands too. Score and cross hatch each plate w/ min 60 grit black sand paper, I used a one handed belt sander w/ 24 grit belt, but be carefull w/ larger sanders. By hand is safest.

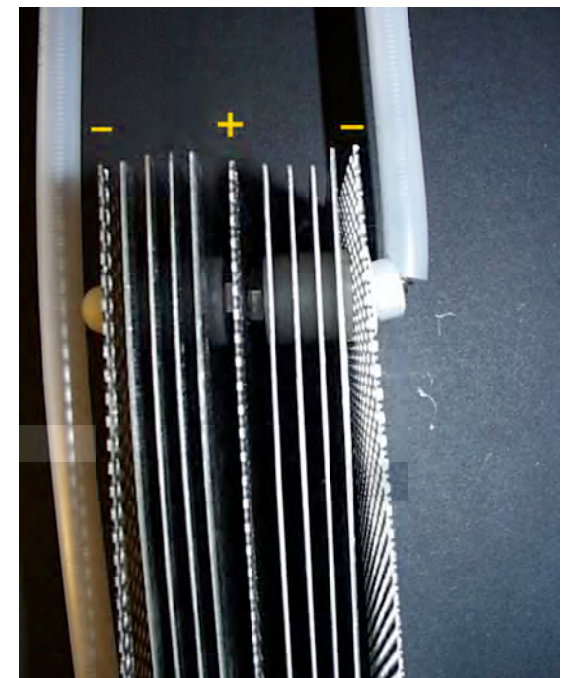
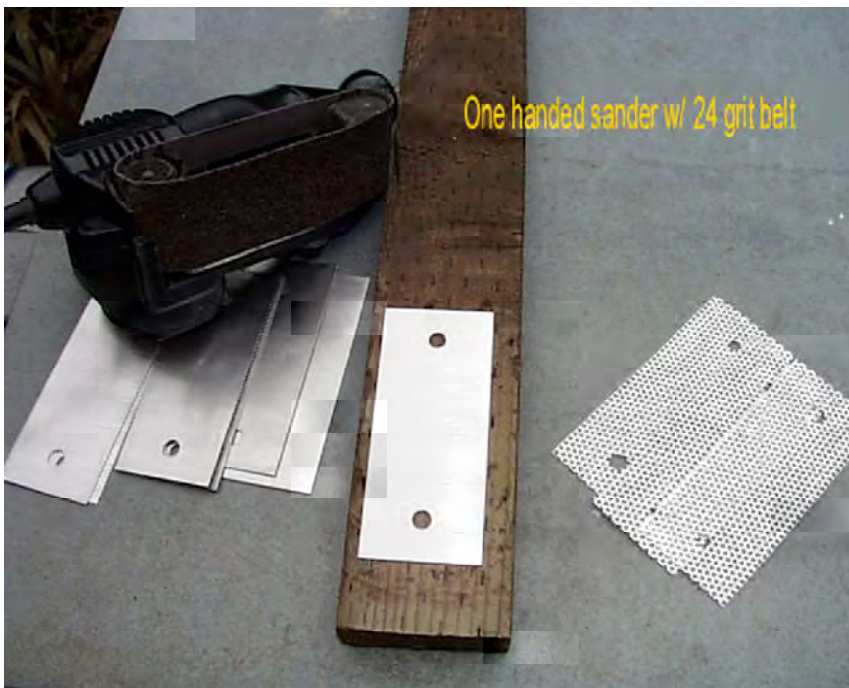

## Assembling Instructions

The "11 Plate Cell" The 11 plate cell runs approx. 2.4 - 2.6 volts between each plate. You will hook up 12 volts at the top of the cell, but the voltage between the plates will be divided up to about 2.4 volts between each plate. Bench test the voltage later by hooking up to battery and taking a voltmeter and test between the top of each plate, one by one, then this part will make more sense to you. This cell will stay clean, no anode sludge should build up, it should stay clean for about 2-3 months of driving. The lower voltage absorbed by the 8 neutral plates makes this cell stay cooler. I will be warm to touch after an hour of driving, but not hand burning hot as a 12 volt cell can get.

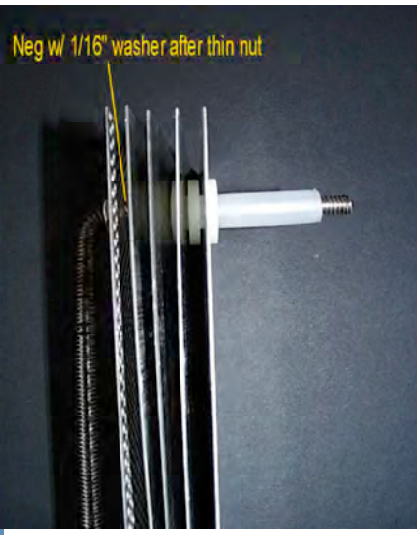
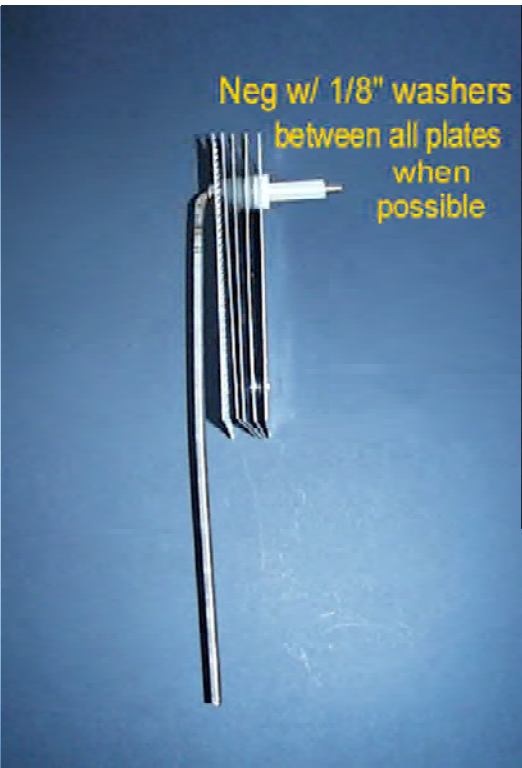

**Assembling Instructions :**

**Step 1**

Start with the 1/4" 316SS threaded and bent rods. Make sure the pre-bent rods are as close to 90% angle. You might have to bend them to a perfect 90 degree angle in a vise with a rag wrapped around the threads to prevent thread damage.

**The longer rod is for the Negative (cathode) & the shorter rod is Positive (anode).**

**Step 1 :Assemble the first cathode plate;**

Thread the first nut as far as it will go, tighten real good, all the way to the 90% bend. Slide the first perforated plate onto the rod followed by another SS thin nut, tighten real good, as tight as you can get it, as if it will never get lose with all the car vibrations and many road trips. Make sure the rod and plate are parallel. Also make sure the larger 3/8" hole is below, the 1/4" punched hole fits the 1/4" rod. Next cut a piece of 1/4" ID tubing with 3/8" of thread showing. Then add a cut lg tubing piece 3/16" to fit over the thin SS nut, see photo, to insulate the nut to the next neutral plate.

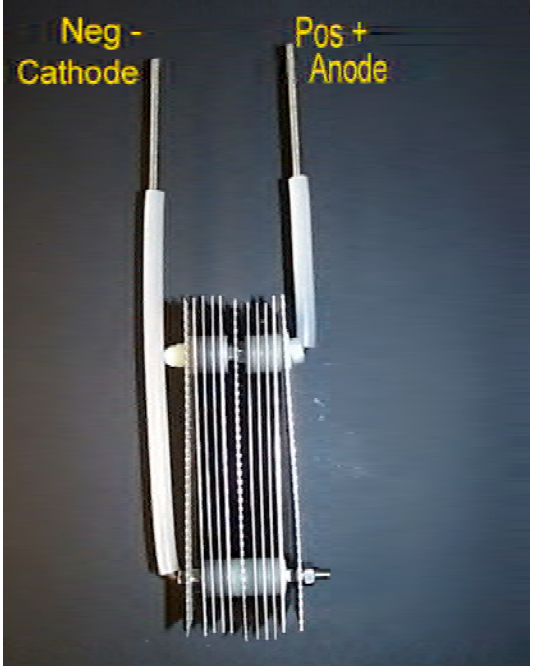

When assembling this cell, remember, the neutral plates never touch each other or any metal, the 3/8" punched holes ride on the 3/8" OD tubing, so it never touches the rod. Even the SS nuts cannot touch, The SS nuts are covered by the larger diameter tubing, the clear 1/2" vinyl tubing, just as long as they isolate from each other. Also you should pre assemble first, take it apart and then re-assemble tightening the SS nuts to the plates as tight as you can get it, and also as parallel to the plate as possible (rod to plate). The idea is once you finish assembling the plates, you will not have to re-do it later, after year of use. Also when using the nylon nuts, don't over tighten, they can strip easily.

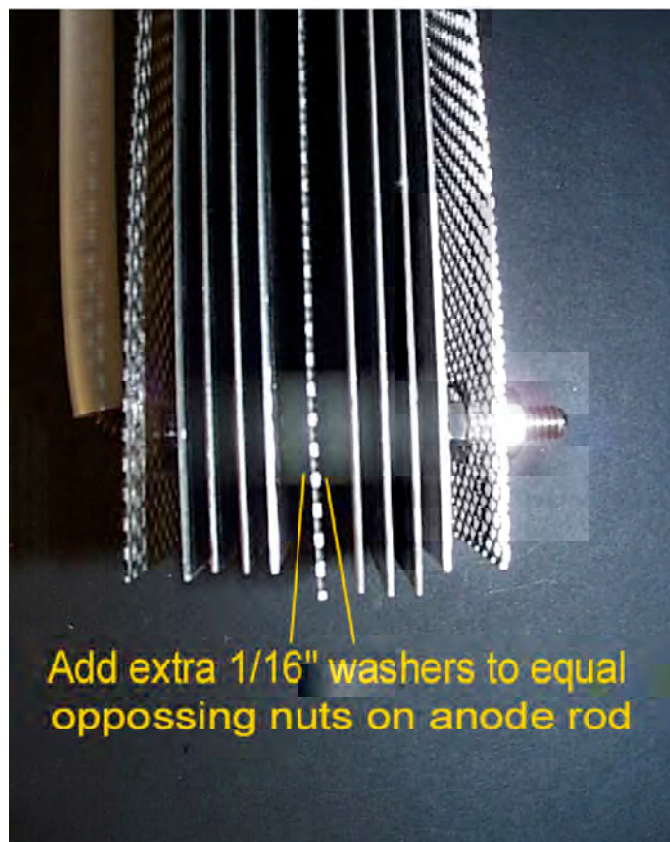
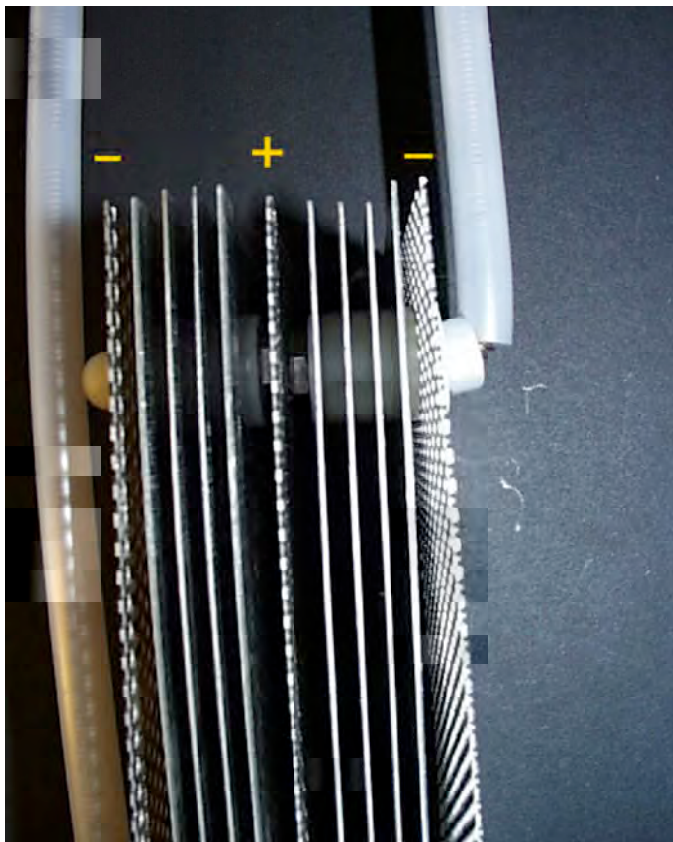

### Step 2 :Assemble the anode plate

Thread on a nylon nut to the bend as far as it will go, carefully. Add a piece of 1/4" tubing a bit longer than half way, you'll trim later. Next add a 1/8 x 3/8" ID nylon washer. {Note, keep this tubing against the nylon nut so the Neg plate NEVER touches this anode rod. Next, add another 1/8" nylon washer & proceed to stack this half w/ 4 neutral plates spacing each w/ a 1/8" washer. Do likewise on the Neg cathode rod, step 1, but adding a long length on tubing to insulate the pos plate added later.

**Step 3:** This shows progress w/ a Neg to plate to start, and four neutral plates, all spaced 1/8" ideally. Negative now half completed, remembering to keep tubing against nut so the beginning neutral remains neutral by not contacting the cathode rod - ever. Ideally, an 1/8" is the optimum spacing @ all plates. When a nut is applied, just add a thin washer in addition to the 1/8" to make equal the distance between each.



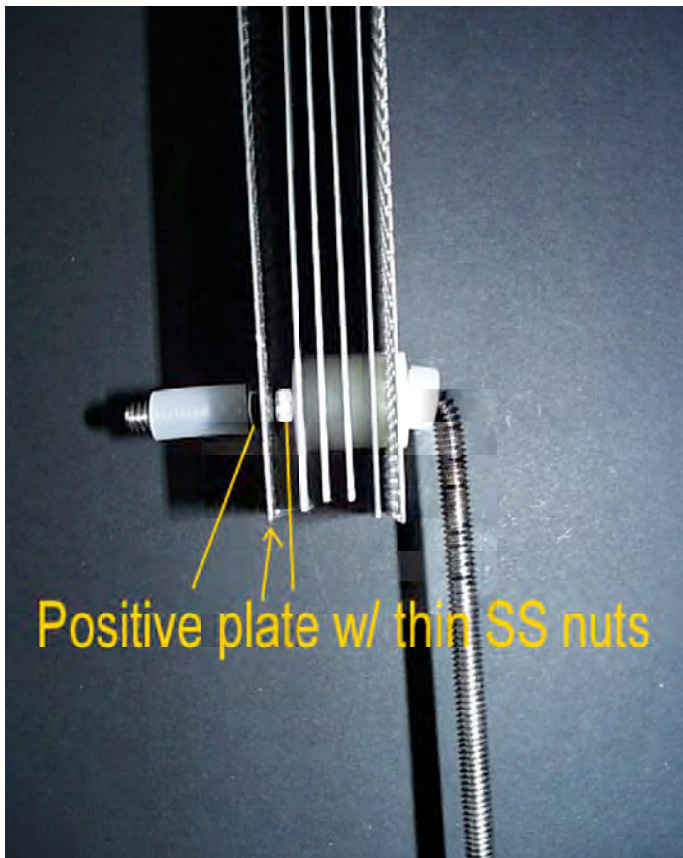

This detail shows Pos - Anode assembly, note that Pos plate is secured w/ a thin nut on either side of the + plate, on the Pos rod. Workout the length of the short pieces of tubing between the center + plate to insulate the neutral & Neg - end plates from the Pos + rod.

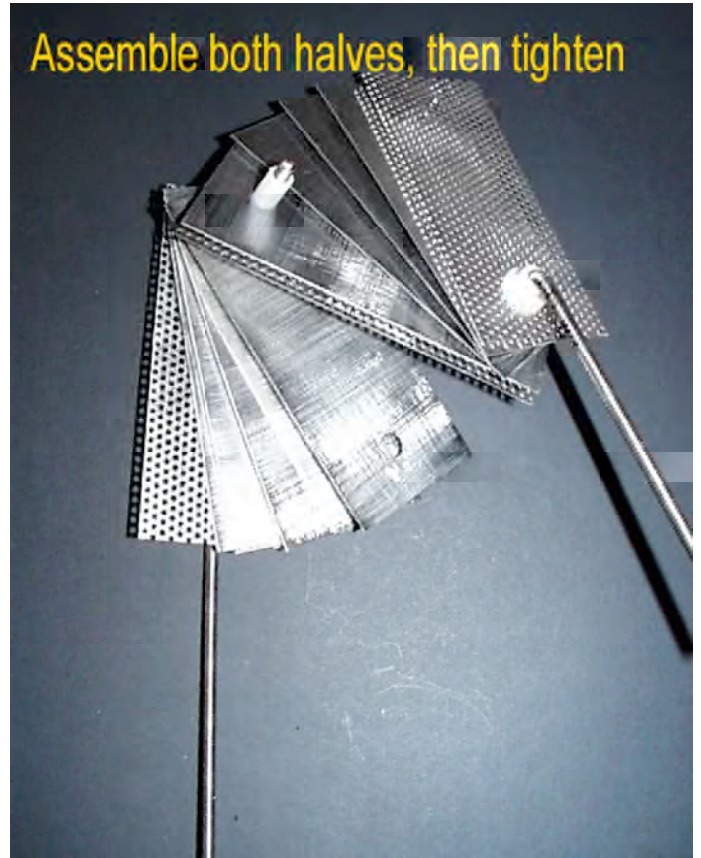

Next, leaving all but the starting nuts loose, the two halves can now be assembled to make the entire unit. I have to stress this issue about tubings that need to end against a nut & washers that slip over tubing need to do just that, because they can & will move until put in their correct order upon tightening the final nuts. Cut plastic tubings to leave enough thread to allow a nut & washer, plus a little at each of the ends.

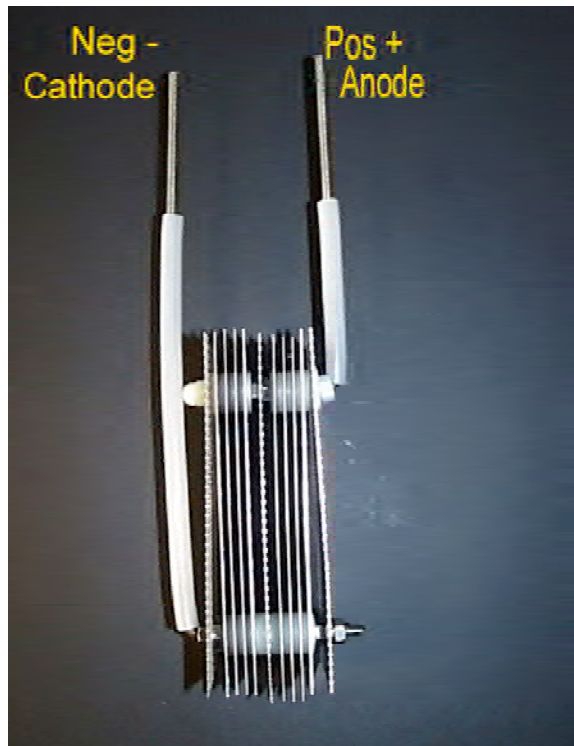

All plates in proper order & note the use of washer size, type, etc. Pos. rod ends w/ a nylon nut, to insulate at Neg. rod w/ tubing. Try to maintain an 1/8" spacing.

Remember the center plate is the Positive plate, it is sandwiched between 2 SS thin nuts. The 2 Negative plates are on the ends. Both the Positive and Neg. plates are the perforated plates.

Remove some material on inside wall surface @ rod hole  
Allows stop nut on rods to slip next to side, without binding

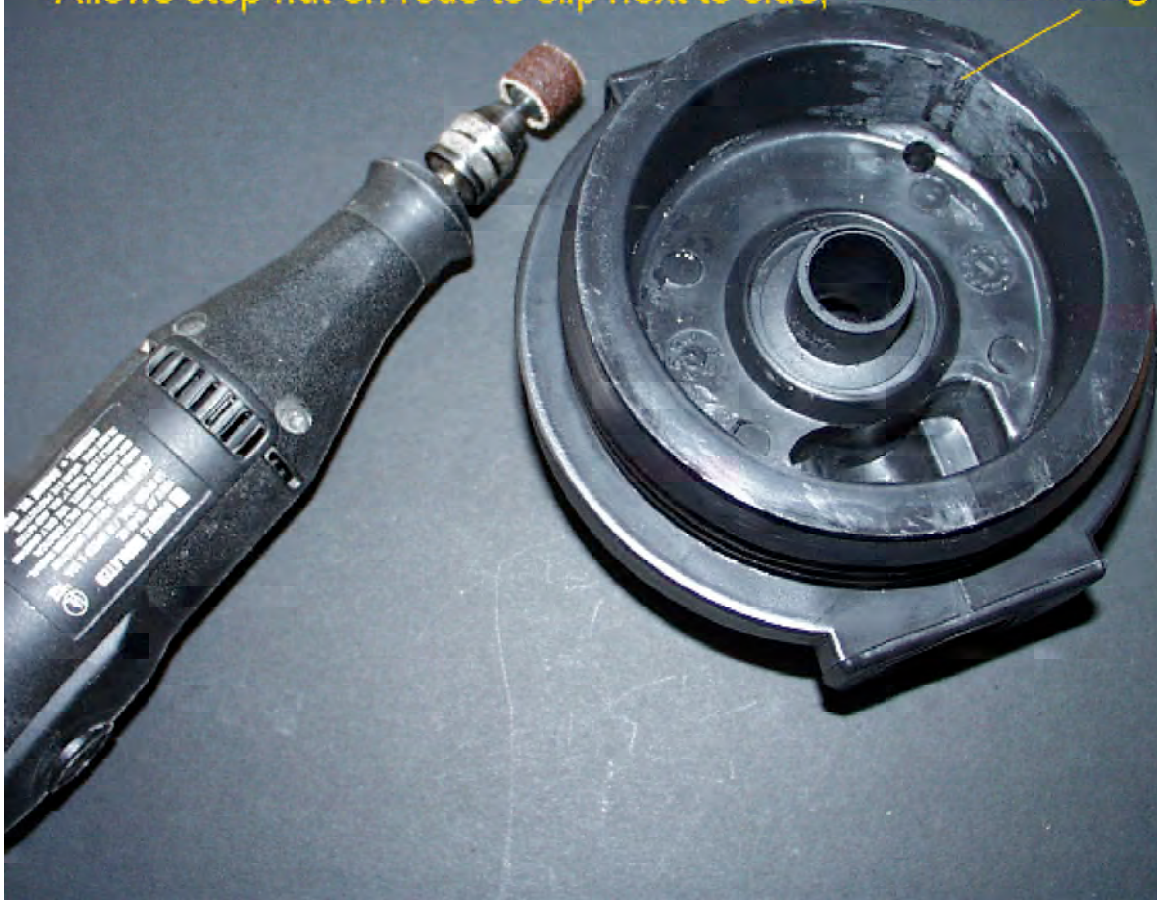

#### Step 4

You'll need to drill two 1/4" holes through the lid from the top, so the rods pass up through the lid & out the top. You'll need to remove some material from the inside wall area at the point where the two Pos. & Neg. rods go through the units' lid. I used a dremel for this w/ a sanding attachment. This allows you to apply a stop-nut -I call it, to each of the rods to position them for centering the finned unit, helps w/ sealing in egas, & just adds to the over-all stability

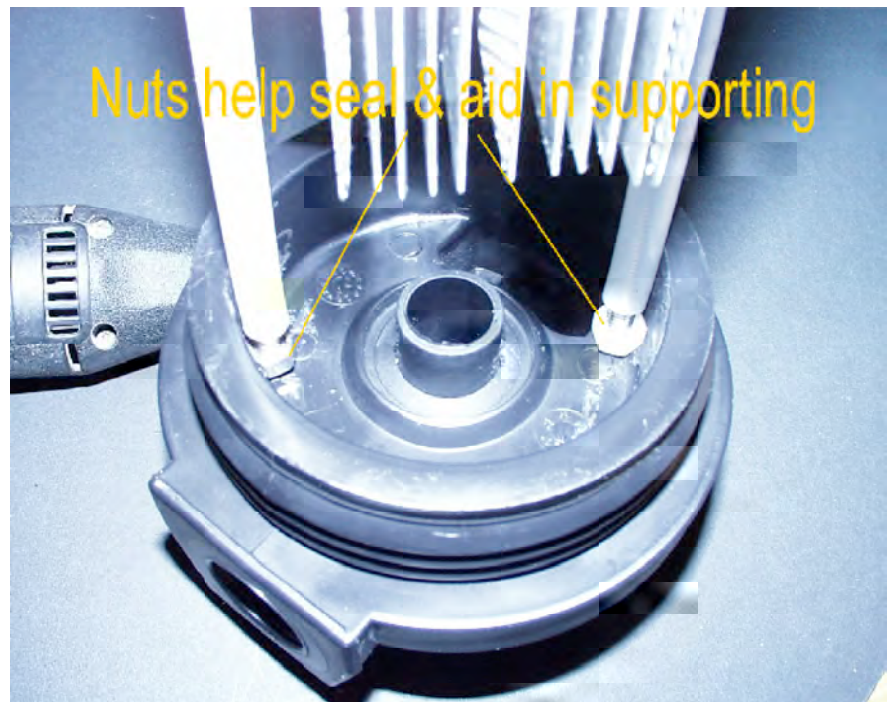

## Step 5 ; Finished

After you've centered up the unit by stopping the nuts in position, as to keep the fins as low as they can go without touching bottom, or scraping the inside of the plastic jar, add and secure the top nuts w/ SS washers on the lid surface first, to insure a, hopefully sealed condition. Next, add another SS washer per post, w/ the correct sized nuts, depending on the amount of threads showing when done. Put your Pos-Neg wire terminals under the last or top washer or add another washer & apply the P or N between the two, either allows you to tighten the top nut without allowing the terminal to spin at the same time, or very little.

This unit is ready for operation. It will be used w/ a bubbler, otherwise we would have added a "one way check valve" vs an open outlet. Enjoy!







# HYDROGEN BOOSTER WIRING

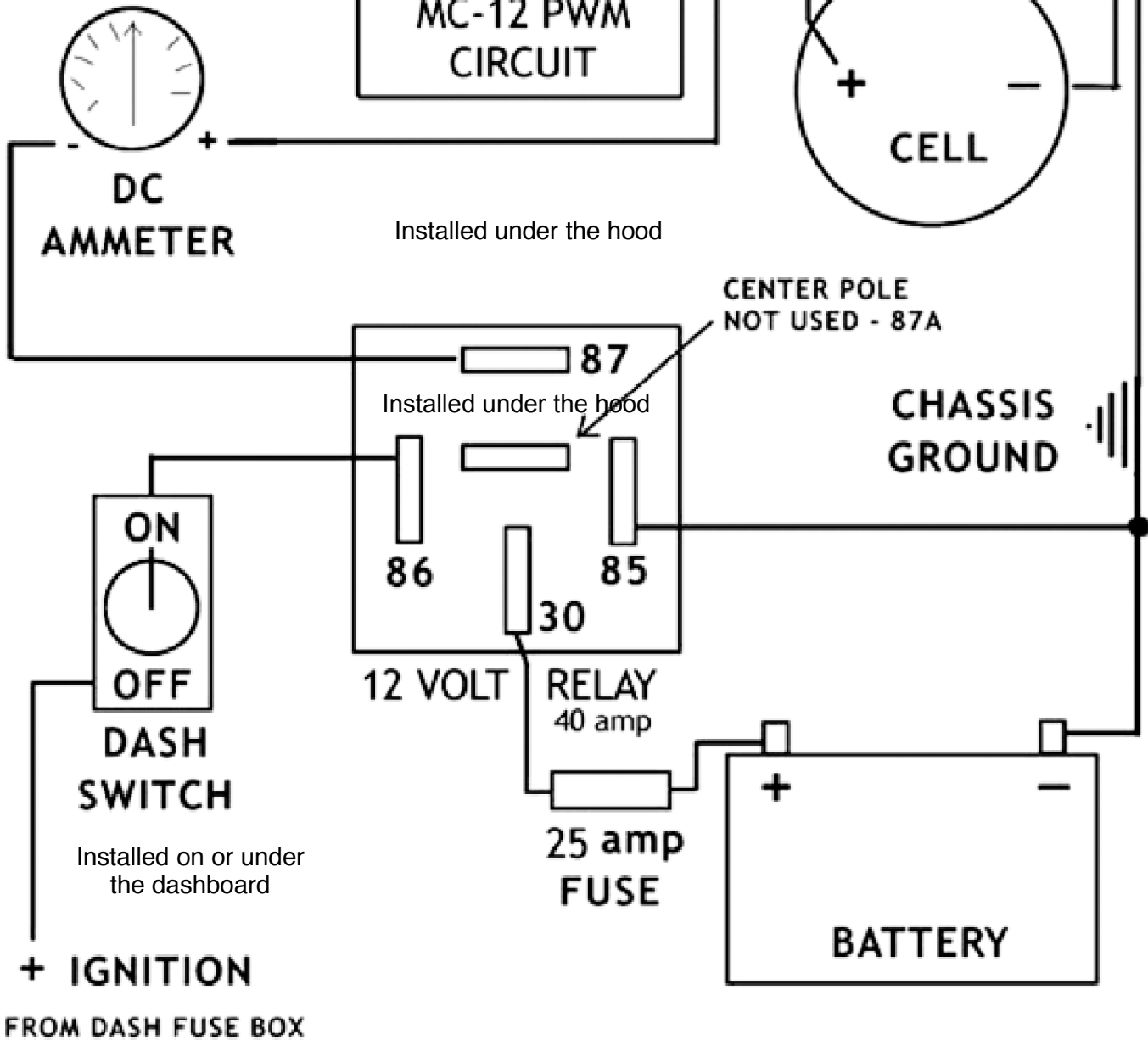

updated 8/24/08

In all these connections use 12 gauge stranded copper wire, can be purchased at a auto parts or hardware store. The ignition to switch and switch to the relay can be lighter wire, 16-20 gauge wire.