

Product Dimensions

PTV142B-2 With Bushing

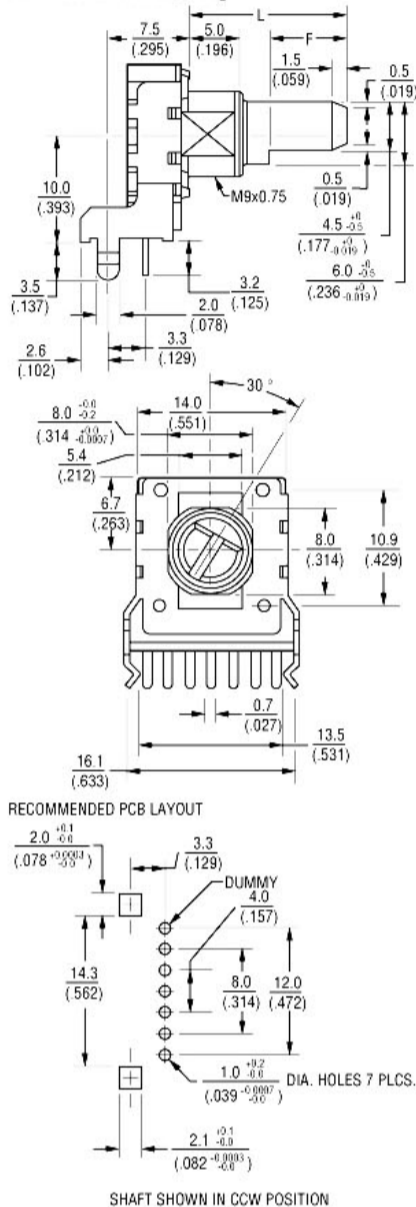

PTV142B-4 With Bushing

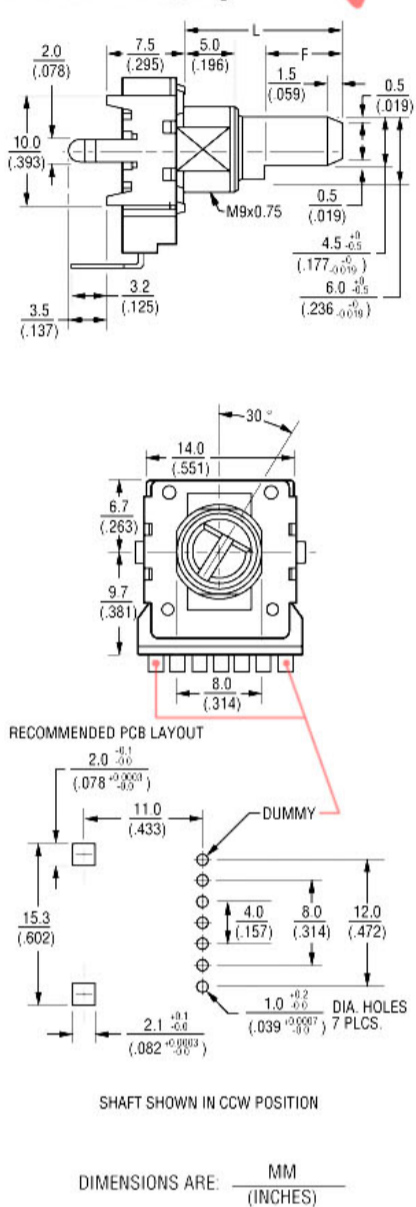

Electrical Diagrams

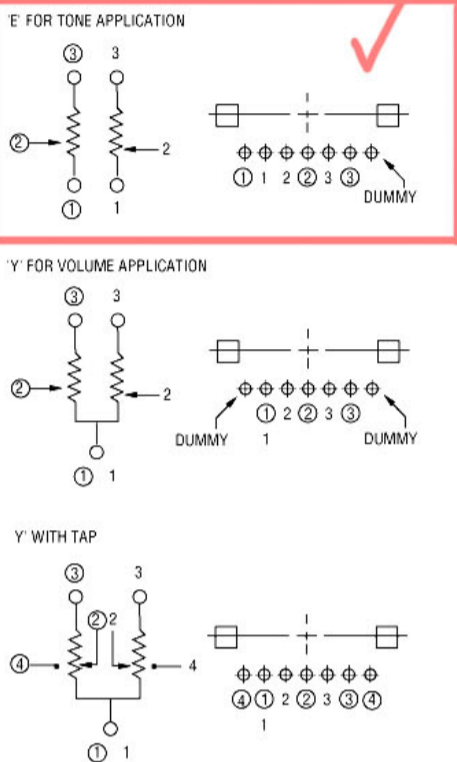

Standard Resistance Table

Resistance (Ohms)	Resistance Code
1,000	102
2,000	202
5,000	502
10,000	103
20,000	203
50,000	503
100,000	104
200,000	204
500,000	504
1,000,000	105

Derating Curve

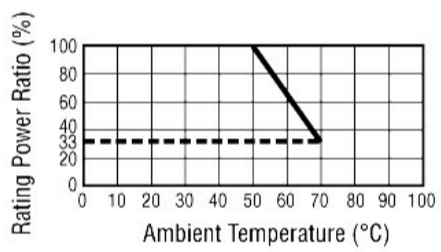

REV. 04/06

Specifications are subject to change without notice. Customers should verify actual device performance in their specific applications.

Electrical Characteristics

TaperLinear, audio
 Standard Resistance Range1 K ohms to 1 M ohms
 Standard Resistance Tolerance±20 %
 Residual Resistance500 ohms or 1 % max.

Environmental Characteristics

Operating Temp.-10 °C to +50 °C
 Power Rating0.05 watt
 Maximum Operating Voltage50 V AC
 Sliding Noise100 mV maximum

Mechanical Characteristics

Mechanical Angle300° ±5°
 Rotational Torque20 to 200 g-cm
 Detent Torque30 to 300 g-cm
 Stop Strength5 kg-cm min.
 Rotational Life15,000 cycles
 Soldering Condition300 °C max. within 3 seconds
 HardwareOne flat washer and mounting nut supplied per potentiometer with bushing

Product Dimensions

PTV142B-2 No Bushing

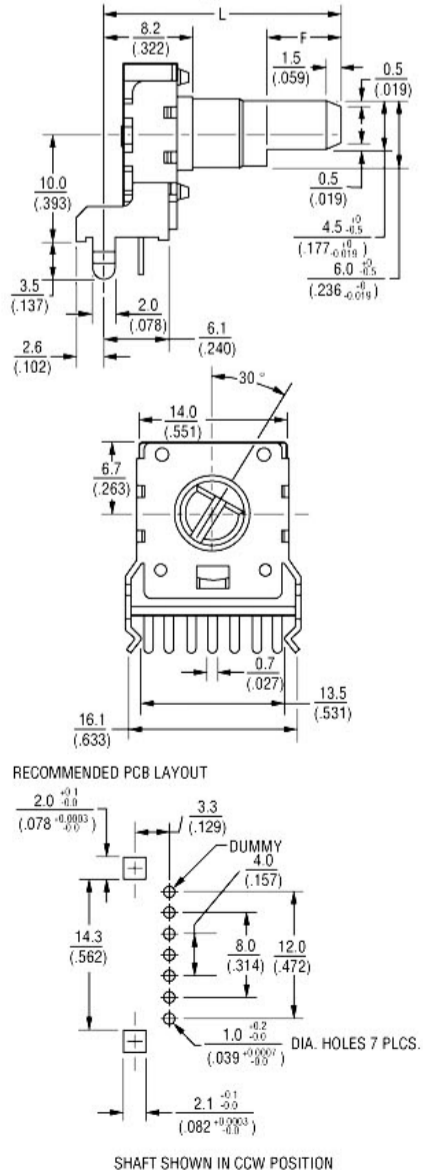

PTV142B-4 No Bushing

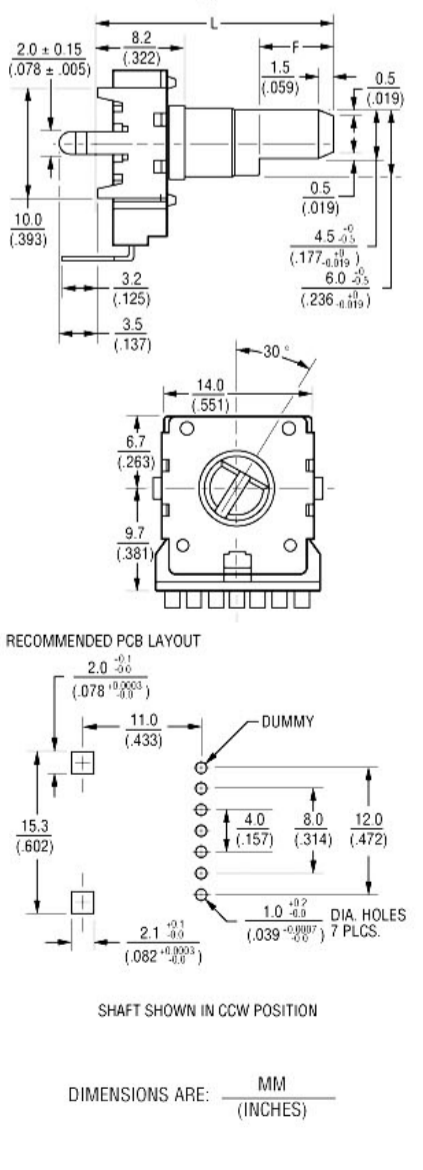

PTV142B40E120AA102

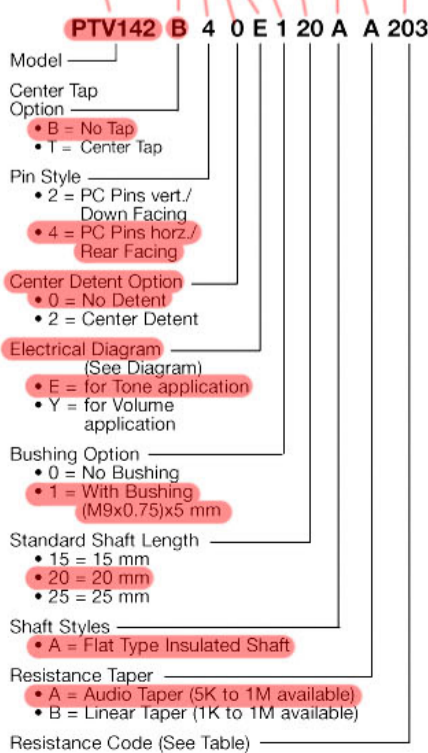

Dimensions Without Bushing

L	15 (.590)	20 (.787)	25 (.984)
F	4.5 (.177)	7 (.275)	12 (.472)